



Liftomatic Material Handling, Inc.

700 Dartmouth Lane
Buffalo Grove, IL 60089

Phone 847 325-2930
Fax 847 325-2959
Toll Free 800 837-6540

OPERATING & MAINTENANCE INSTRUCTIONS FOR THE LIFTOMATIC MODEL DCM DRUM HANDLING ATTACHMENT

Operating Instructions

To operate the Liftomatic DCM unit, simply slide the forks of the lift-truck into the fork pockets of the DCM attachment. (If the operator is using carriage mounted units, remove the forks of the lift-truck, and slide the CM-DCM units into place on the carriage). For all fork-mounted units, the safety chain should be attached to the lift-truck prior to using the attachment(s). If units are equipped with Liftomatic's exclusive Quick-Claw® safety restraint system, slide your forks into the fork pockets and pick the unit off the ground to secure the attachment to the lift-truck.

To operate the DCM, raise the unit slightly off the floor (one or two inches). Center the black (or gold zinc coated) clamping heads on the drums to be picked up, tilt the carriage of the lift-truck slightly forward (approximately two to three degrees), and gently make contact between the clamping heads and the drums. While maintaining contact on the drums with the attachment, raise the carriage of the lift-truck straight up (**DO NOT TILT THE FORKS/CARRIAGE BACK**).

As the drums are lifted off the ground (or pallet), the operator (from his/her seat on the lift-truck) should verify that all clamping heads have securely engaged each drum (both clamping heads should be parallel with the tops of the drums). If one or both heads are sitting at a severe angle, the drums should be set back down, repositioned, and picked up again. This will provide the operator with a positive, secure clamp on each drum. The drums can then be tilted back for transport.

In order to release the drums, the operator should bring the attachment(s) back to parallel with the ground, and simply reverse the procedures stated above.



Visit the Parrot @
www.liftomatic.com



Liftomatic Material Handling, Inc.

700 Dartmouth Lane
Buffalo Grove, IL 60089

Phone 847 325-2930
Fax 847 325-2959
Toll Free 800 837-6540

Maintenance Instructions

1. On a **daily** basis, each operator should check the Liftomatic DCM attachment to verify all fasteners (cotter pins, snap rings, hair pin clips, etc.) are in place. Also, a spot check to be sure the unit does not have any missing or broken parts (pins, springs, fasteners, etc.) should be performed. This can be accomplished by spending a minute or two to rotate each head in all directions, as well as depressing the lower jaws to be sure that all parts move properly and spring back into resting position without difficulty.
2. Liftomatic attachments are completely mechanical, and require **LUBRICATION ON A WEEKLY BASIS**. Standard WD-40 or a “light grade oil” are recommended. Spray down the entire head assembly, **specifically the jaws, links, and connecting pins inside the inner housings (part number #2097)**. Clevises and connecting components (universal body, etc.) should also be lubricated.

To ensure that inner components do not collect large amounts of dirt, dust, or chemical particles, the clamping heads should be removed at least once a month (more often in heavy dust/dirt environments), and soaked/scrubbed in a non-acidic based cleaning solution. After cleaning, the unit should be thoroughly lubricated per above directions.

3. All DCM's (which come standard with belt cradles) should be inspected to ensure the belt (pad) is in place and properly tightened. Please note that belts loosen during daily use and **should be checked prior to each shift**. If belts are torn or tearing, they should be replaced immediately. A broken or badly torn belt provides little or no support to the drum sidewall.
4. On a **monthly** rotating basis, Liftomatic drum handling attachments should be taken out of service for thorough analysis. This will entail removing the clamping head (Part Number 4006 on enclosed parts list) from the frame, and completely disassembling the head. Each part should be inspected for cracks, breaks, elongating holes (in the links, clevises, etc.), pin and spring wear, as well as missing parts. This process should be performed for each of the clamping heads in use. Any “questionable” parts (as it relates to their integrity) should be replaced as soon as possible.

Liftomatic drum handling attachments do require periodic preventative maintenance. The above schedule should be followed as indicated for the equipment to perform at its fullest potential. A preventative maintenance program will allow your Liftomatic drum handling attachment(s) to lead a long and productive life, ensuring high levels of safety and productivity in all of your daily drum handling routines. Please consult your nearest Liftomatic office or representative to enroll in our “Service-Plus™” preventative maintenance program today. We look forward to assisting you further. Liftomatic’s main headquarters phone is: 800-837-6540. You may visit us on the web as well at: www.liftomatic.com. Email to: edberg@liftomatic.com.

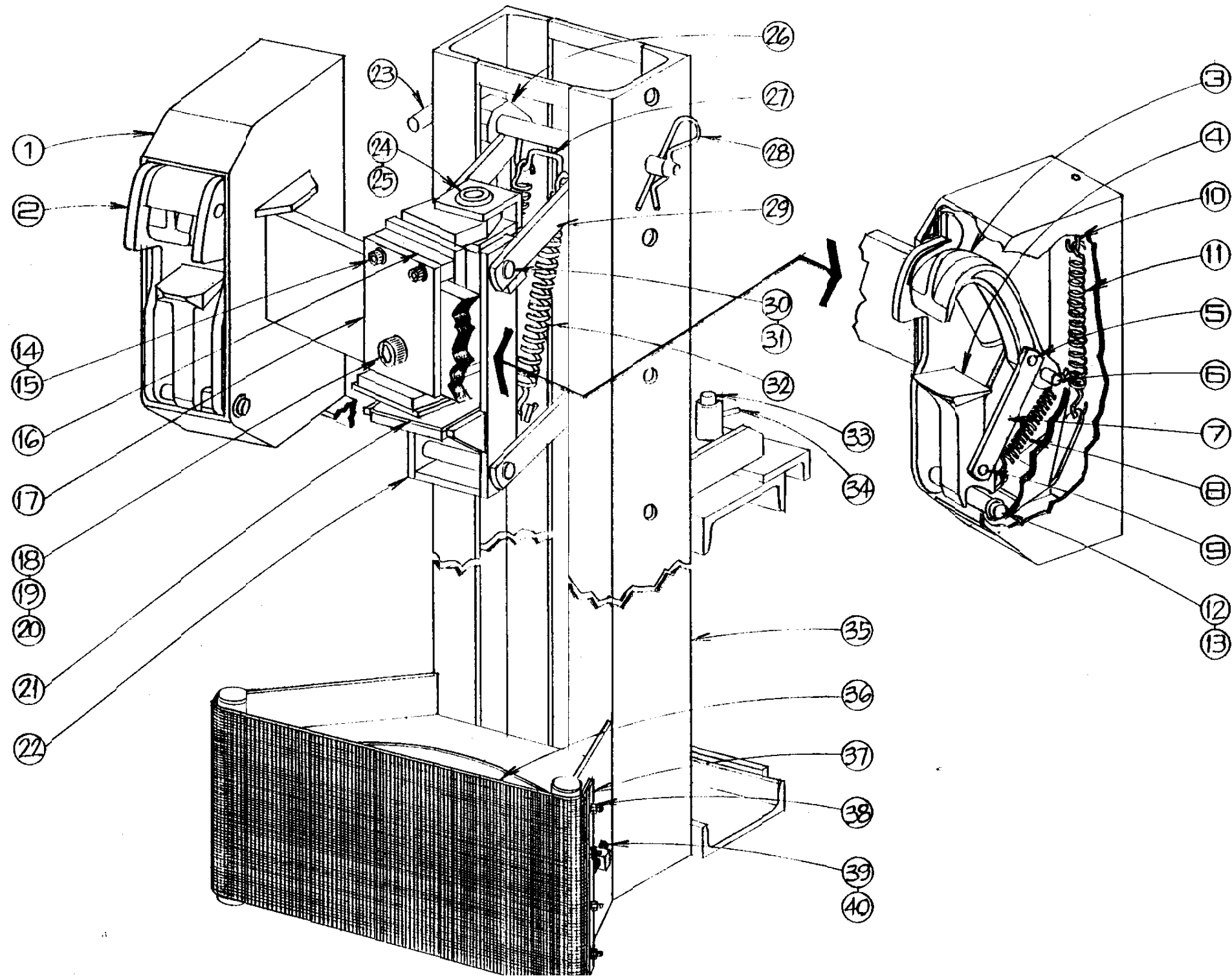



Liftomatic Material Handling, Inc.

700 Dartmouth Lane
Buffalo Grove, IL 60089

Phone 847 325-2930
Fax 847 325-2959
Toll Free 800 837-6540

DISASSEMBLY PROCEDURE -- LIFTOMATIC MODEL DCM-BC

- I. To remove the clamping mechanism assembly (Part Number 4005, Figures 1-13) from the universal body (Figure 17):**
 - A. Unfasten two cap screws (Figure 14), and slide out the spacer (Figure 16).
 - B. Unfasten the trunnion screw (Figure 18), and then lift out the clamping assembly from within the universal body (Figure 17).

- II. To remove the universal body (Part Number 2029, Figure 17) from the clamping assy.:**
 - A. Unfasten the cotter pin (Figure 25) from its retaining pin (Figure 24).
 - B. Pull or drive the pin (Figure 24) out of the remaining assembly. This will free the universal body.

- III. To remove the universal carrier (Part Number 2027, Figure 22):**
 - A. Unhook and remove the clevis spring (Figure 32) and hook (Figure 27).
 - B. Detach cotter pins/snap rings (Figure 31) from one end of the two remaining pins (Figure 30), and pull/drive the pins out. The universal carrier can then be removed.

- IV. To remove the slides (Part Number 7007-1, Figure 26), and the clevises (Part Number 2023, Figure 29) from the belt cradle frame:**
 - A. Unfasten the hairpin clip (Figure 28) off the adjustment pin (Figure 23).
 - B. Pull the adjustment pin out and lift the slides/clevises up along the side channel framework until removed from the frame.

- V. To take apart the clamping assembly (Part Number 4005, Figure 1-13):**
 - A. Remove the housing spring (Figure 11) off the inner and outer housings.
 - B. Detach cotter pin/snap ring (Figure 13) off pin (figure 12), and pull/drive the pin out. The inner and outer housings (Figures 1 and 2) can now be separated.
 - C. Drive out pins (Figures 6 & 9) to remove components inside the inner housing.

- VI. To remove the belt cradle frame (Part Number 4019, Figure 35) from the fork adapter slide-on-mounting (on adjustable models only):**
 - A. Pull up and hold the roll pin (figure 34), then slide the belt cradle frame to either side of the slide-on-mounting until removed.

To assemble the above components/assemblies, utilize the reverse procedure.

If additional assistance is needed, please contact Liftomatic Material Handling, Inc.

PH: 800-837-6540 or FAX: 847-325-2959.



Liftomatic Material Handling, Inc.

700 Dartmouth Lane
Buffalo Grove, IL 60089

Phone 847 325-2930
Fax 847 325-2959
Toll Free 800 837-6540

POINTERS FOR PROPER MAINTENANCE AND OPERATION OF LIFTOMATIC “*Parrot-Beak*®” ATTACHMENTS

Similar to any mechanical piece of equipment, Liftomatic drum handling attachments will require periodic maintenance. The following “pointers” should be followed on a regular basis (as indicated) for the equipment to perform at its fullest potential.

** On a daily basis, each operator should check his/her drum-handling device to be sure all fasteners (cotter pins, snap rings, hair pin clips, etc.) are in place. Also, to be sure the unit is not missing any other pins or springs, or if any of the components have broken, a spot check should be done. This can be accomplished by rotating each head in all directions, and depressing the jaws downward to see that all parts move properly and spring back into resting position without difficulty.

** All DCM’s (which do come standard with belt cradles) should be inspected to ensure the belt cushion is in place and properly tightened. Please note that belts will loosen during daily use and should be checked prior to each daily shift.

** Liftomatic attachments are completely mechanical, and require LUBRICATION ON A WEEKLY BASIS. Standard WD-40 or any light grade oil is recommended. Simply spray down the entire head assembly, specifically the jaws, links, and connecting pins inside the inner housings. Additional lubrication should be done in high volume or heavy usage areas.

** To ensure that inner components do not get “gunked up” with dirt, dust, chemical particles, etc., the clamping heads should be removed at least once a quarter (more often in heavy dust/dirt environments), and soaked/scrubbed in a non-acidic based cleaning solution. After cleaning, the unit(s) should be thoroughly lubricated.

** On a quarterly rotating basis, Liftomatic drum handling attachments should be taken out of service and thoroughly inspected for part wear/breakage. This will entail removing the clamping mechanisms from the frame, and complete disassembly. Each individual part should be inspected for welding cracks or breaks, missing or broken parts, elongating holes (in the links, inner housings, clevises, etc.), as well as pin and or spring wear. Liftomatic can provide this service should your facilities wish to enroll in our “[Service Plus™](#)” maintenance program.

Should these items be followed on a regular basis, your Liftomatic drum handling attachments should lead a long and productive lifetime. Please consult your nearest Liftomatic office and account manager for further assistance (PH: 800-837-6540) or email: edberg@liftomatic.com



Liftomatic Material Handling, Inc.

700 Dartmouth Lane
Buffalo Grove, IL 60089

Phone 847 325-2930
Fax 847 325-2959
Toll Free 800 837-6540

PREVENTATIVE MAINTENANCE PROGRAM BULLETPOINTS FOR LIFTOMATIC "PARROT-BEAK®" DRUM HANDLING EQUIPMENT

Liftomatic would like to take a moment and outline our cost saving preventative maintenance program for you. This program has been established to maintain the safety, longevity, and productive characteristics of our "**Parrot-Beak®**" drum handling products while directly reducing your overhead expenditures. Establishing a continuous program with Liftomatic is simple--just give us a call! We will outline the number of products in use, determine the highest usage areas within your plant, and tailor a plan specific to your needs on an annual or semi-annual basis.

Liftomatic's "PM" Program will Include:

- Designating which units and plant areas offer the highest use and drum handling volume.
- Upgrading each unit to 2004/2005 quality standards including padded belt cradles, heavy-duty belts, and "Weather-Beak™" (*heavy duty coated*) components where possible.
- Repainting framework for high visibility and protection from chemical corrosion. Unit "numbering" also available if desired (see below).
- Establishing new I.D. tags (or a numbering system) for simple product identification in the field.
- A detailed breakdown and analysis of the entire "Parrot-Beak®" clamping system, belts, frames, etc. This information is put in writing and sent to your company's designated employee for review.
- Suggestions will be made to repair or replace parts/assemblies where needed and or cost effective.
- Equipment trade-in allowances also available in the majority of cases.

Additional information will be exchanged between your company and Liftomatic before, during, and after the PM program. Many of the important "highlights" are simply outlined above.

Liftomatic looks forward to working with you and increasing your levels of safety and productivity. Feel free to contact us at (PH): **800-837-6540** or info@liftomatic.com.

CHOOSE LIFTOMATIC... "TOUGH JOBS DEMAND TOUGH EQUIPMENT!"