



d y n a m i c

maneuverable

Work productively

The rugged, reliable SG-R Series delivers power & performance that gets your job done, even in the smallest worksite areas. The compact overall dimensions, tight turning radius & low collapsed mast height gets you where you need to go.

Rugged & reliable performance is delivered from a high powered diesel engine coupled to a dependable transmission & axles increasing productivity and reducing downtime.

The SEE-THRU® all roller 2-stage or 3-stage mast offers superior visibility for increased safety and efficiency.

SG-R low profile rough terrain forklift



SG-R low profile rough terrain forklift

Lift capacities of 5,000 or 6,000 @ 24" load centre

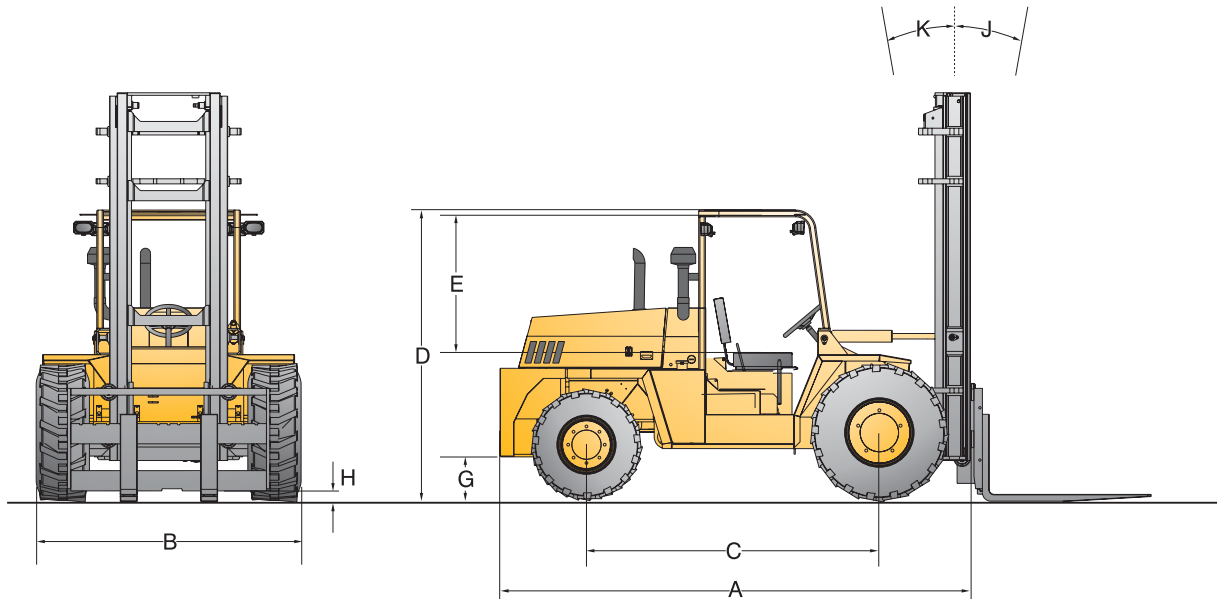

Model	Ref	SG-50R	SG-60R
Lift capacities @ 24 inch load centre		5 000 lbs	6 000 lbs
Overall length (without forks)	A	141"/3581 mm	
Overall width	B	78"/1981 mm	
Wheelbase	C	87"/2210 mm	
Height to top of overhead guard (std)	D	85"/2159 mm	
Height to top of overhead guard (low)	D	75"/1905 mm	
Distance from seat to OHG (std)	E	45"/1143 mm	
Distance from seat to OHG (low)	E	39"/990 mm	
Outside turning radius		2WD: 168"/4267 mm; 4WD: 178"/4521 mm	
Aisle width 90° stacking		2WD: 256"/6502 mm; 4WD: 266"/6756 mm	
Frame underclearance	G	11"/279 mm	
Mast underclearance	H	12"/203 mm	
Mast sideshift		6"/152 mm	
Mast tilt - forward	J	15°	
Mast tilt - rearward	K	10°	
Gradeability		25%	
Tire size type & size (standard pneumatic)		Drive: 15 - 19.5 - 12 ply; Steer: 12 - 16.5 - 10 ply	
Engine manufacturer & model		Perkins 1100 Series (1104C-44) diesel naturally-aspirated	
Cylinders		4	
Engine output (gross power)		83 hp @ 2200 rpm	
Peak torque		223 ft-lbs @ 1400 rpm	
Transmission type (standard)		4-speed power reversing synchroshuttle	

Because of our constant dedication to product improvement, all specifications are subject to change without notice.

— All Sellick forklifts meet or exceed all ANSI B56.6 safety standards. —



Sellick Equipment Limited • P.O. Box 1000/358 Erie Street North • Harrow, Ontario, Canada • N0R 1G0 • 519-738-2255 • sellick@mnsi.net

